

PIPING DIAGRAM AROUND STEAM TURBINE

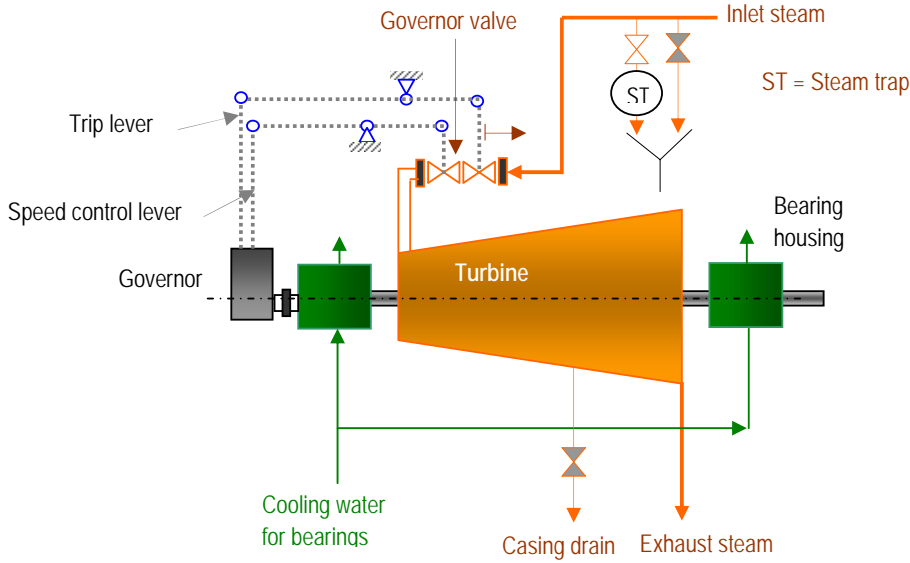

PIPING DIAGRAM AROUND SINGLE STAGE BACK PRESSURE STEAM TURBINE TYPICAL

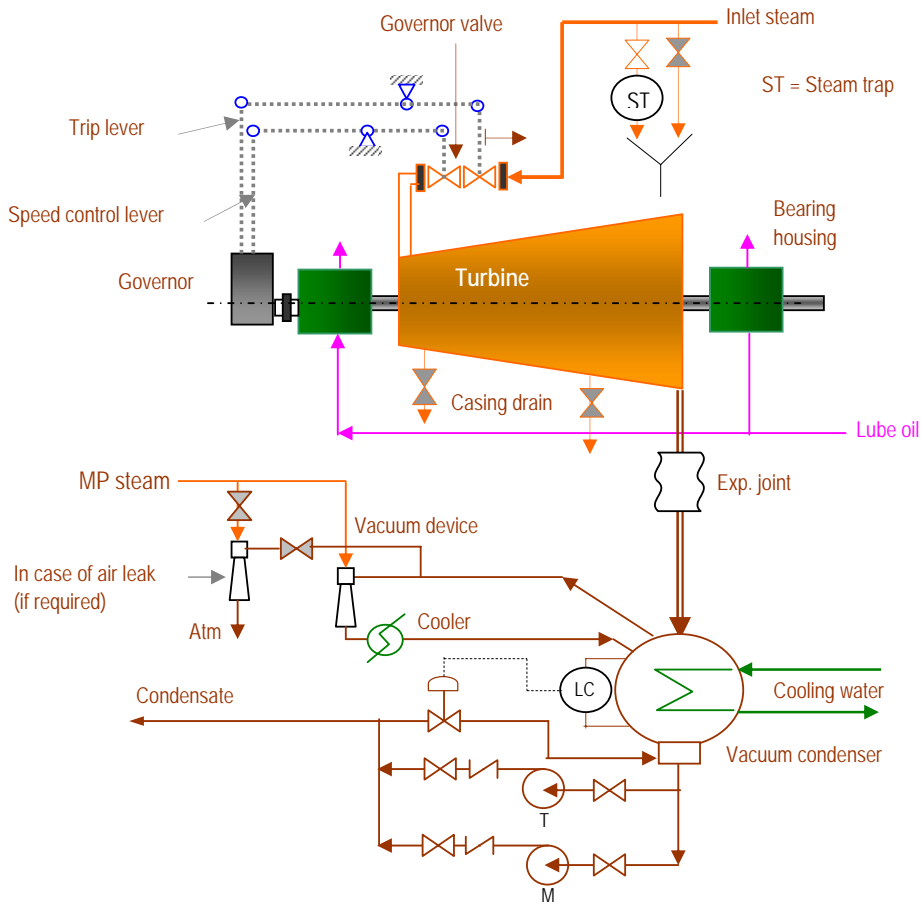

PIPING DIAGRAM AROUND CONDENSING STEAM TURBINE TYPICAL

GOVERNING SYSTEM

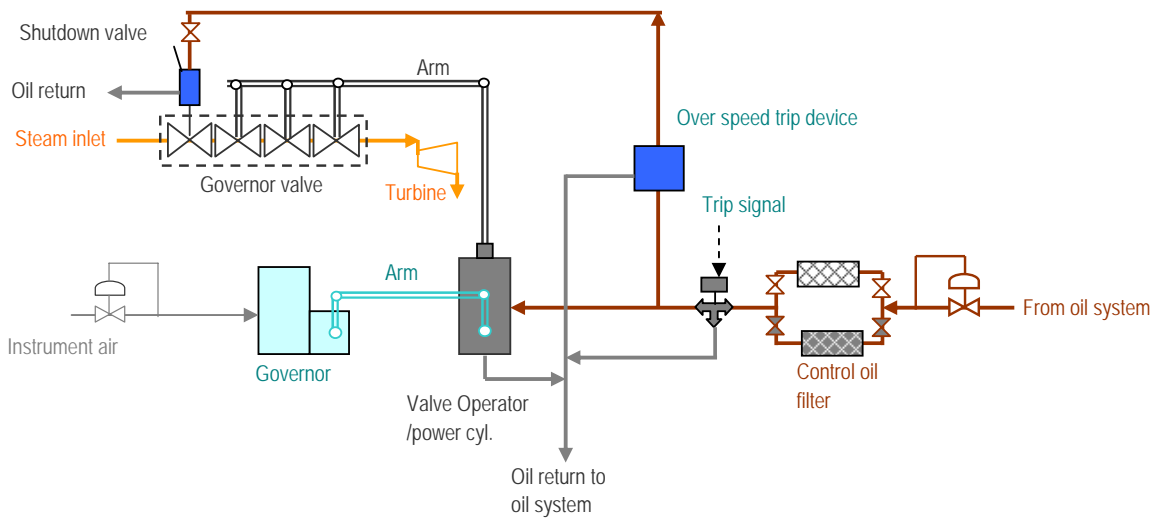

GOVERNING SYSTEM DIAGRAM, MECHANICAL GOVERNOR

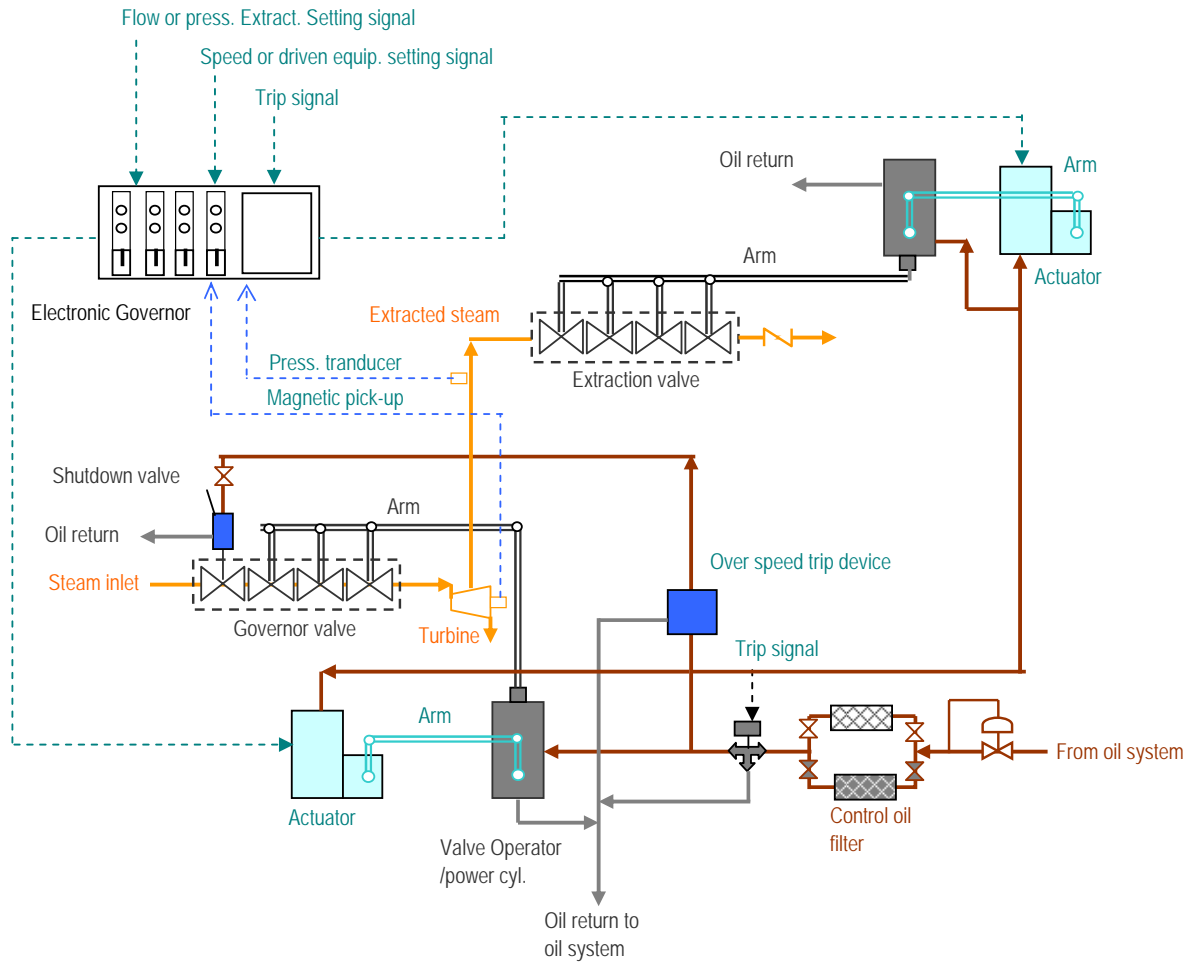

GOVERNING AND EXTRACTION SYSTEM DIAGRAM, ELECTRONIC GOVERNOR

OIL SYSTEM

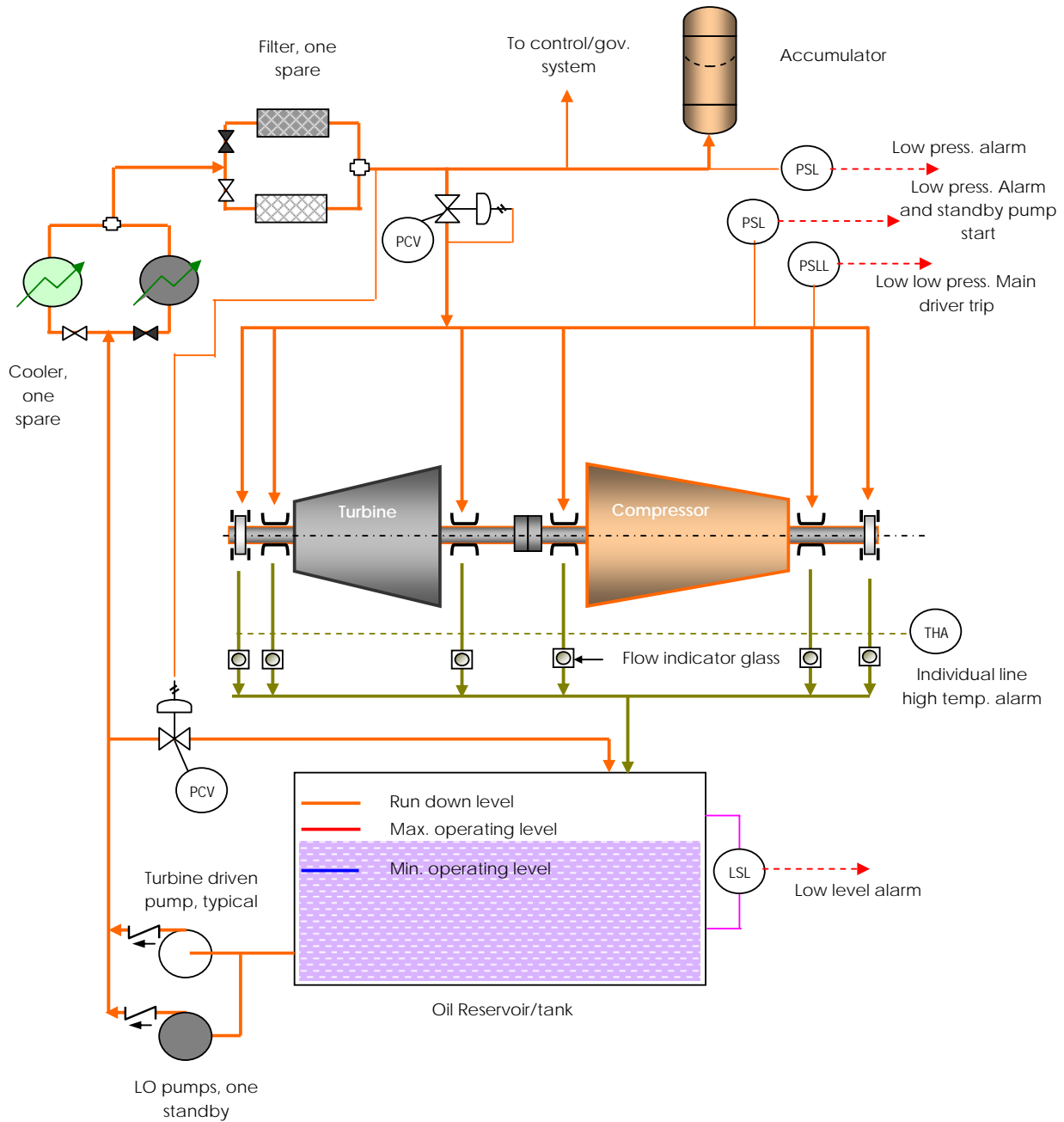

SIMPLIFIED OIL SYSTEM FOR STEAM TURBINE
TYPICAL, COMMON OIL SYSTEM